



100
1910 - 2010

DURHAM - DUPLEX

SHEFFIELD - ENGLAND

**Industrial Blade, Machine Knife
and Hand Knife Manufacturers**

Razor Sharp since 1910



DURHAM - DUPLEX

S®
MADE IN
SHEFFIELD





SHEFFIELD - ENGLAND



Industrial Blade, Machine Knife and Hand Knife Manufacturers



Company Profile

Durham-Duplex is a world leader in the design, manufacture and distribution of machine knives and industrial razor blades. As a family owned manufacturing company based in Sheffield, England since 1910, **Durham-Duplex** is very proud of its "Made in Sheffield" pedigree and now sells to over 40 countries direct and through our dedicated international distributors. Thus a century after the first blade was sold Durham Duplex's quality products are still sought after global commodities and the company is looking forward to the next 100 years of innovation and excellence.

Quality

Durham-Duplex has a time proven quality assurance program with an experienced inspection team at each facility. This is supported by our own ISO based "in line" quality assurance regime that ensures that all knives are continually checked in production to ensure the highest standards of quality and accuracy.

Service Ethos

Durham-Duplex values its customers and has a large and experienced staff to ensure personal and efficient service.

Call now to experience the Durham-Duplex difference.

Tel: +44 (0) 114 2432 313

Fax: +44 (0) 114 2444 329

sales@durham-duplex.co.uk

export@durham-duplex.co.uk



Razor Sharp since 1910

Machine Knives

Durham-Duplex provides a comprehensive stock of punches, straights, circular and serrated machine knives, manufactured from carbon, stainless, alloy, high speed and powder steels to fulfil the modern factories requirements in almost every industrial sector. Furthermore, our extensive technical experience is always available to assist in custom knife design, upgrading and problem solving.



Vertical Packaging Knives



We stock a extensive range of precision ground serrated knives in parallel, tapered and apex profiles available with standard, tear notch or easy open tooth configurations to complement all modern packaging equipment.



Horizontal Packaging Knives



Flow wrap, shrink pack and over wrap knives in toothed, scissor, straight, and zig-zag profiles with progressive or tear notch options. We also carry an extensive range of stock parts for rapid delivery.



Machine Knives

Food Processing

The demands of the food industry requires an extra special touch. Whether processing or packaging food products customers require a blade with clean, corrosion resistant edges and traceability. To meet this industry standard **Durham-Duplex** offers the highest grade magnetic stainless and high chrome tool steels across the majority of our knife range.



Food Packaging

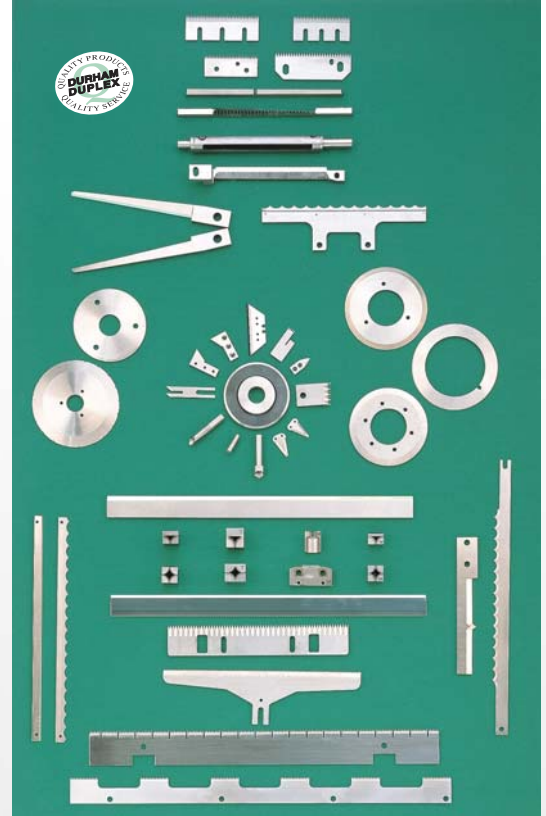

Fibre Processing, Plastic Film & Paper Converting

Converting man made film and fibre products requires an array of cutting requirements to effectively slit, perforate, chop and recycle the end product. **Durham-Duplex**'s innovative and unique range of industrial razor blades are used by the world's largest manufactures to ensure the consistency and quality of their products. Additionally our investment in innovation means that we are always at the fore-front of technology when it comes to preparing machine knives for processing the material into bags, sacks, tape, labels and sachets.



Polythene & Paper Bag & Sack Production

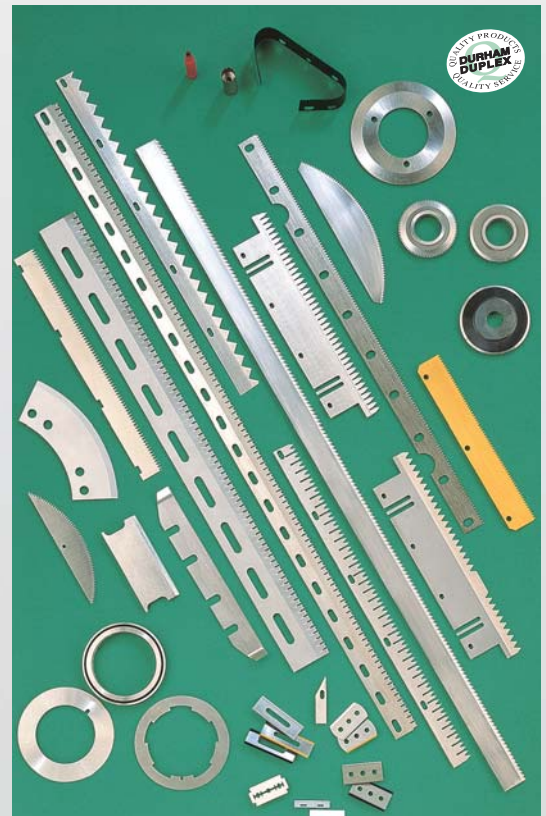

Machine Knives

Vacuum Packaging & Case Taping

Printing & Graphics

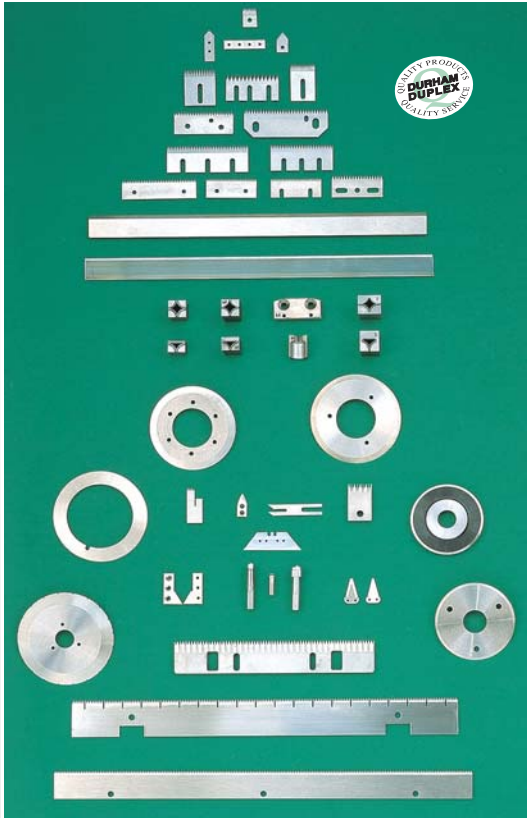

Durham-Duplex has a wide range of knives for use in the print and sealing areas. These include high precision vacuum punches, fly knives, serrated web press knives, film cut off knives, core cutters, crush cutters, dish slitters, tape sealers and bottom knives.

Specialised Manufacture of Unique Machine Knives



Durham-Duplex's bespoke manufacturing facilities enable the company to develop prototypes and competitive short run products for machine builders, end users and multinationals alike. Investment in modern manufacturing equipment means that production runs of up to one million blades can be delivered on time and correct to specifications.

Straights, zig zags, flat circles, punches, coiled strip, dish circulars, serrated strip, granulators, pelletisers, tube cutters, serrated pieces are all available so if it cuts, slits, slices, pierces, perforates, chops, chips, dices, scrapes, mixes, folds, macerates or creases then we can probably help you improve it.

Safety Knives and Hand Knives

The Durham-Duplex range of hand held utility knives are designed for today's environment. Strong, durable, uncomplicated and effective whilst remaining easy on the pocket. Where safety is an issue we have a multitude of different approaches from spring loaded designs to hidden blades and restricted apertures to ensure that every job can be completed quickly and safely without damage to product or person.



Trimming Knives & Scrapers Hand Knives

- | | | |
|----------|----------------------------|------------------------------|
| 1. SN111 | 10. SN106 | 15. Small Hobby Knife (HT50) |
| 2. SN112 | 11. Plastic Scraper (HT40) | 16. Hobby Knife (HT51) |
| 3. SN113 | 12. Metal Scraper (HT41) | 17. Hobby Knife (HT52) |
| 4. SN115 | 13. Snippy (HT80) | 18. Carton Knife (HT60) |
| 5. SN116 | 14. Mini Scraper (HT42) | |
| 6. SN101 | | |
| 7. SN102 | | |
| 8. SN103 | | |
| 9. SN104 | | |

- | | | |
|----------------------------------|------------------------------|---------------------------------------|
| 1. Disposable Slim Knife (HT93) | 5. Folding Slim Knife (HT22) | 9. Rapide Retractable |
| 2. Fixed Slim Knife (HT20) | 6. Rapide Fixed (HT19) | 10. Fixed Trimming Knife (HD9) |
| 3. Retractable Slim Knife (HT23) | 7. Bi-Angle (HD29) | 11. Retractable Trimming Knife (HD14) |
| 4. Fixed Slim Knife (HT24) | 8. Rapide Plus Retractable | |

Safety Knives

- | | |
|-----------------------|---------------------------|
| 1. Retro Light (HT6) | 9. Polyglide |
| 2a. Springer (rh) | 10a. Duoslit |
| 2b. Springer (lh) | 10b. Duoslit Blade Master |
| 3. Retro (HT15) | 11. Polysafe |
| 4. Easy Change (HT28) | 12. Supaslit Plus |
| 5. Supaslit Deluxe | 13. Ambi-Safe (HT944) |
| 6. Supacut | 14. Polysafe Plus |
| 7. Polyslit | |
| 8. Polyslit Plus | |



Blade Dispensers

- | | |
|-------------------------------------|--|
| 1. Deluxe 100 Blade dispenser | 6. 9mm Snap-off Blade Tube |
| 2. Deluxe 50 Blade Dispenser | 7. WBG 201 Single Edge Blade Dispenser |
| 3. Std 100 Blade Dispenser | 8a. 10 Blade Dispenser |
| 4. WBG 203 Injector Blade Dispenser | 8b. 10 Blade Dispenser |
| 5. 18mm Snap-off Blade Tube | 9. Economy Blade Dispenser |

Carton Opening Knives

- | | |
|------------------------------|------------------------------------|
| 1. Morri-Cut (HT915) | 6. Split Ring String Cutter (HT81) |
| 2. Micro Adjust Knife (HT5) | 7. Ideal Carton Knife (HT62) |
| 3. Ambi-Safe HD (HT63) | |
| 4. Edge Protector Knife | |
| 5. Ring String Cutter (HT81) | |

Disposal Bins

- | |
|------------------------------|
| 1. Large Blade Disposal Bin |
| 2. Medium Blade disposal Bin |



The following products are not available to German customers or for sale/resale into Germany. Our company does not ship or distribute these products into Germany. Knife numbers: Safety knife items 2a, 2b, 9 and 14 and Carton Opening Knife items 2 and 4. Die folgenden Produkte werden nicht an deutsche Kunden angeboten und nicht für Verkauf oder Wiederverkauf in Deutschland. Unser Unternehmen liefert diese Produkte nicht nach Deutschland: Messer Nr. "Safety Knife" 2a, 2b, 9 und 14, sowie "Carton opening knife" 2 und 4.

Industrial Blades

Durham-Duplex's "Made in Sheffield" credentials confirm it as one of the world's best industrial razor blade manufacturers. By making precision ground strip to the most exacting tolerances the company's products are able to cope with the demands of modern production methods and all trade requirements. We offer an extensive standard blade range in carbon, stainless and high grade alloys, complemented by the latest in long life, low friction PVD coatings, powder technology carbide and ceramic blades. In addition, our utility range can be supplied *branded* with your company name and logo, on the body, the blade or the packaging and is offered in a selection of presentation, utilitarian and safety packaging.

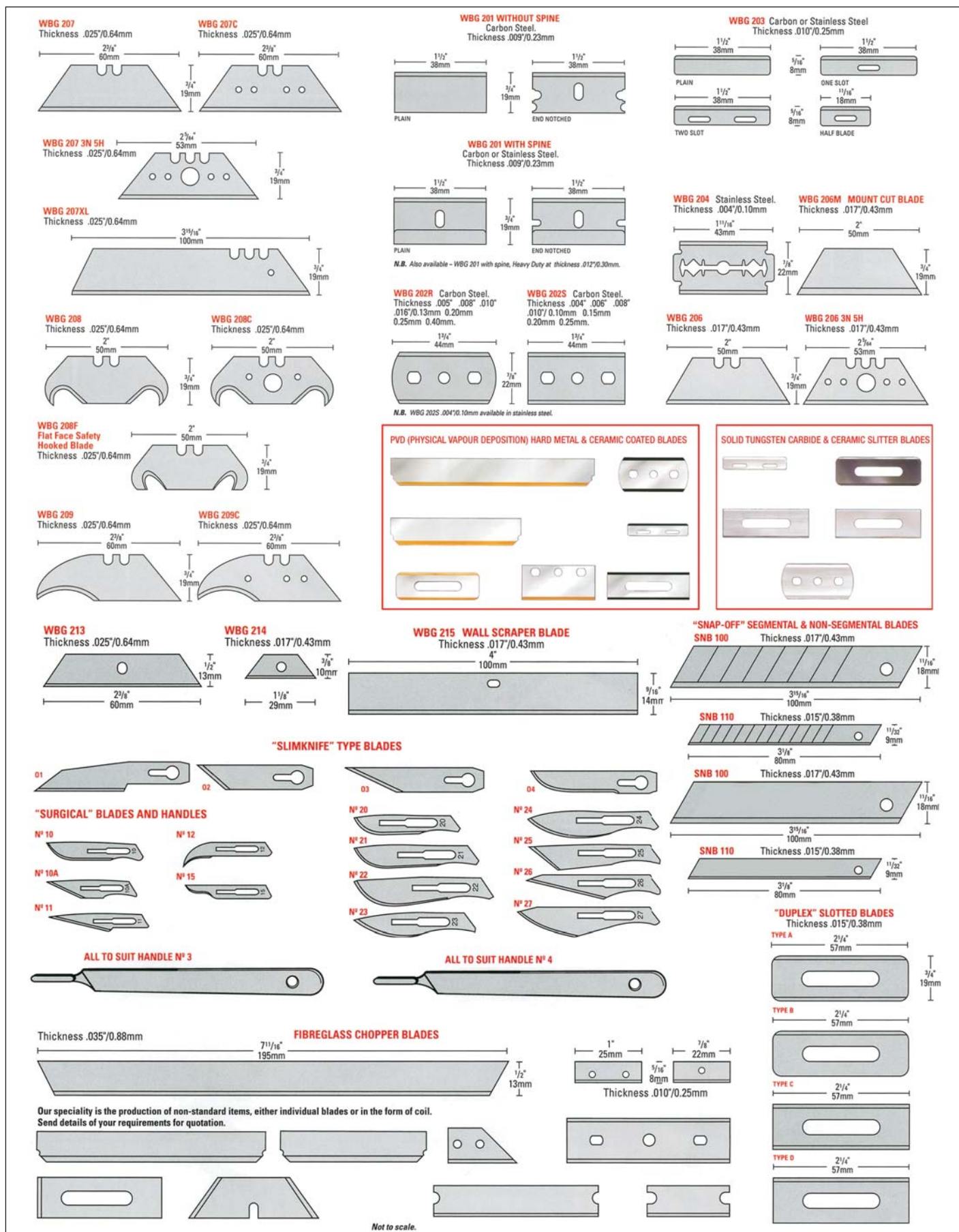

WBG 207 Thickness .025"/0.64mm
WBG 207C Thickness .025"/0.64mm
WBG 201 WITHOUT SPINE Carbon Steel. Thickness .009"/0.23mm
WBG 203 Carbon or Stainless Steel Thickness .0107"/0.25mm
WBG 207 3N 5H Thickness .025"/0.64mm
WBG 201 WITH SPINE Carbon or Stainless Steel. Thickness .009"/0.23mm
WBG 204 Stainless Steel. Thickness .004"/0.10mm
WBG 206M MOUNT CUT BLADE Thickness .017"/0.43mm
WBG 207XL Thickness .025"/0.64mm
WBG 202R Carbon Steel. Thickness .005" .008" .010" .016"/0.13mm 0.20mm 0.25mm 0.40mm.
WBG 202S Carbon Steel. Thickness .004" .008" .008" .010"/0.10mm 0.15mm 0.20mm 0.25mm.
WBG 206 Thickness .017"/0.43mm
WBG 206 3N 5H Thickness .017"/0.43mm
WBG 208 Thickness .025"/0.64mm
WBG 208C Thickness .025"/0.64mm
WBG 208F Flat Face Safety Hooked Blade Thickness .025"/0.64mm
WBG 209 Thickness .025"/0.64mm
WBG 209C Thickness .025"/0.64mm
WBG 213 Thickness .025"/0.64mm
WBG 214 Thickness .017"/0.43mm
WBG 215 WALL SCRAPER BLADE Thickness .017"/0.43mm
"SNAP-OFF" SEGMENTAL & NON-SEGMENTAL BLADES
SNB 100 Thickness .017"/0.43mm
SNB 110 Thickness .015"/0.38mm
SNB 100 Thickness .017"/0.43mm
SNB 110 Thickness .015"/0.38mm
"SLIMKNIFE" TYPE BLADES
"SURGICAL" BLADES AND HANDLES
ALL TO SUIT HANDLE N° 3
ALL TO SUIT HANDLE N° 4
FIBREGLASS CHOPPER BLADES
"DUPLEX" SLOTTED BLADES
TYPE A Thickness .015"/0.38mm
TYPE B
TYPE C
TYPE D

PVD (PHYSICAL VAPOUR DEPOSITION) HARD METAL & CERAMIC COATED BLADES

SOLID TUNGSTEN CARBIDE & CERAMIC SLITTER BLADES

Our speciality is the production of non-standard items, either individual blades or in the form of coil. Send details of your requirements for quotation.

Not to scale.

Machine Knives available for the following equipment

3M	Comat	Hesser	Record
ACM	Comexi	Hosakawa Bepex	Redpack
A.M.P. Rose	Condux	Hutt	Robert Bosch/
Alan Duffy	Cope & Cope	Ilapak	Hamac
Albert Frankenthal	Crabtree Vickers	Illig	Robopack
Alpine	Creusot Loire	IMA	Rollem
Alpma	Cryovac	Inpack	Rose Forgrove
Amal	Cumberland	Iwema	Rota Schnieder
Amplas	Datum Redpack	Kampf	Rovema
Aquarius	DCM-Holweg	Kawashima	Saldoflex
Armour	Delpro	Kestrel	Sandiacre
Arpeco	Delta	KFC	Sapal
Arvor	DEV Industries	Kister	Schib
Ashe	Dew	Klöckner Hänsel	Schroeder
AST	Didde	KBA	Servowrap
Astra	Dienes	Komori	SIG/Sapal/Doboy/
Atlas	Dixie Union	Krones	Maypack
Aucouturier	Doboy	La Meccanica	Simionnato
Autopak	Dreher	Lemo	Sireix
Autowrapper	Dusenbery	Lenox	Sollich
Europack	Eberle	Linotype	Solna
B.L.	EDL	Little David/	Spag/DCM
Baker Perkins	Eldan	Padlocker	Spooner-Vicars
Ballinger Rawlins	Eldec	Lumms	Strachan Henshaw/
Bedo	Endoline	Madeley	Beasley French
Beringer	Erema	Maidstone	Swissvac
BFB	Euro-Pharma	Maja	Tevopharm
Bielloni	Eurosicma	Man Roland	Timpson
Bielomatik	Falcon	Marden-Edwards	Tiromat
Biro	FAS	Marubeni	Titan
Blackfriars	Finn & Fram	Meiji	Townsend
Bosch/Hamac	Fischer Krecke	Miele	Tria
Bowe	FMC	Molins	Ulma
Burnley Packaging	Fuji	MTB	United Bakery
C.G. Automation	Gainsborough	Multivac	Equipment
C.S.S.	Gammerler	Munchy	Urschel
Cable & Wire	GBE Lerner Burgess	Nebiolo	UVA Butler
CAM	GD	Oakwood	Varlet
Cameron	Gloucester/Gloenco	Omorì	Vits
Carle Montanari	Goebel	Optima	Volpak
Cassoli	Grasselli	Otem	VMK
Cavanna	GSP	PFM	Webber
Cermex Ouest	Gunter Stiegler	Pallmann	Weston White
Cerruti	Harnden	Parkland	Wiema
Cevenini	Harris	PCMC	Wifag
Cem	Hassia-Redatron	Perini	Windmoller &
CIMP	Hayssen	Perkin	Holscher
Clan	Hayssen Europa	Pierret	Wright Machinery/
Cobden Chadwick	Heidelberg	Polymer/UPM	Monobag
Coemter	Heights Design	Preveiro	Woodman
Columbus McKinnon	Herbold	Printex	Zezma
ComarmMarchetti	Hercules	Rapid	Zirkon (Polygraph)

THE DURHAM DUPLEX PRODUCT RANGES, SUITABLE FOR ALL CUTTING, SLITTING, CHOPPING, PERFORATING AND SCRAPING APPLICATIONS, ARE THE MOST COMPREHENSIVE AVAILABLE. HOWEVER, YOU MAY HAVE A REQUIREMENT FOR AN ITEM NOT SHOWN ON OUR LITERATURE, BUT WHICH FITS OUR GENERAL PRODUCT GROUPINGS, IF SO:-
PLEASE SEND DETAILS AS WE WILL ALMOST CERTAINLY BE ABLE TO SUPPLY

DURHAM - DUPLEX

312-314 PETRE STREET, SHEFFIELD S4 8LT. ENGLAND.
TEL: +44 (0) 114 243 2313 FAX: +44 (0) 114 244 4329
E-mail: sales@durham-duplex.co.uk
Website: www.durham-duplex.com

